

Marina Trajković¹, Dragoslav Šumarac², Marina Mijalković¹, Dušan Krajčinović³

OTKRIVANJE OŠTEĆENJA ODREĐIVANJEM DINAMIČKIH KARATERISTIKA DAMAGE DETECTION VIA DYNAMIC CHARACTERISTICS DETERMINATION

Originalni naučni rad / Original scientific paper

UDK /UDC: 620.1

Rad primljen / Paper received: 21.9.2005.

Adresa autora / Author's address:

¹) Građevinsko-arhitektonski fakultet, Niš

²) Građevinski fakultet, Beograd

³) Arizona State University, Tempe, Arizona, U.S.A.

Ključne reči

- oštećenje konstrukcije
- dinamičke karakteristike
- krutost
- metoda identifikacije podprostora
- monitoring vibracija

Izvod

Promene dinamičkih karakteristika (krutosti, prigušenja) kao posledice istorije konstrukcije (erozija, trenje, zamor, unutrašnja oštećenja i prslina) utiču na smanjenje pouzdanosti konstrukcije kao i na njenu upotrebljivost ili, u najgorem slučaju, mogu dovesti do njenog kolapsa. Imajući u vidu da je oštećenje konstrukcije malo ili unutar sistema, stoga ne može biti detektovano vizualno, u radu je predložena koristan ne-destruktivan postupak za određivanje oštećenja preko dinamičkih parametara - monitoring vibracija konstrukcije.

UVOD

Erozija, trenje, zamor materijala, unutrašnja oštećenja i prslina prouzrokuju postepenu degradaciju dinamičkih karakteristika konstrukcije: krutost sistema slabi, a povećava se prigušenje sistema. Razvoj degradacije može dovesti do nesposobnosti konstrukcije za bezbednu i zadovoljavajuću upotrebljivost koja je od nje očekivana i garantovana u fazi projektovanja. Rezultati mogu biti ozbiljni, čak katastrofalni; važna inženjerska konstrukcija se u jednom trenutku iznenada sruši usled gubitka krutosti i otpornosti, što mora biti blagovremeno sprečeno i izbegnuto. Da bi se otkrila bilo koja greška i odredio stepen pouzdanosti konstrukcije neophodna je redovna kontrola i procena stanja.

Rano otkrivanje oštećenja i njegova lokalizacija dozvoljavaju da održavanje i popravke budu ispravno programirani, a samim tim smanjeni i troškovi.

Tokom poslednje dve decenije metoda identifikacije podprostora postala je predmet mnogih istraživanja širom sveta kao jedna od najmlađih metoda za otkrivanje oštećenja konstrukcije uz praćenje vibracija.

Ona je jedna od tzv. metoda *identifikacije sistema*, tj. metoda inverzne dinamičke analize, u kojoj se informacije

Keywords

- structural damage
- dynamical characteristics
- stiffness
- subspace identification method
- vibration monitoring

Abstract

The change of dynamic parameters (stiffness, damping), as a consequence of structural history (erosion, friction, fatigue, internal damages and cracks), has an impact on decrease of reliability and serviceability of a structure or, drastically, causes its collapse. Having in mind that structural damage is small or embedded in the system, hence the detection cannot be done visually, one useful non-destructive procedure for damage determination by dynamic parameters evaluation - vibration monitoring of the structure

INTRODUCTION

Erosion, friction, fatigue, internal damages and cracks cause gradual degradation of the dynamic structural properties: the stiffness of the system is weakened, whereas the damping is increased. The development of degradation can cause inavailability of the system supply safe and satisfactory use as expected and guaranteed by design. The results may be serious, even disastrous; an important engineering structure at some stage suddenly collapses due to loss of its stiffness and strength, which must be in proper time prevented and avoided. In order to detect the defect and determine reliability level of the structure regular inspection and assessment of engineering structures condition are required.

Early damage detection and their localization allow maintenance and repair to be properly programmed, thereby minimizing the costs.

In last two decades subspace identification method became the issue of many researches worldwide, as one of the youngest methods for structural damage detection based on vibration monitoring.

It is one of so-called identification system methods, i.e. inverse dynamic analysis method, in which the information

o karakteristikama konstrukcije, npr. krutost i prigušenje, dobijaju na osnovu eksperimentalnih ulazno/izlaznih podataka. Cilj ovog rada je provera metode kao i otkrivanje položaja oštećenja u konstrukciji.

METODA IDENTIFIKACIJE PODPROSTORA ZA MODEL PROSTORNOG STANJA

Posmatramo konstrukciju koja je pobuđena pomoću m pobuda pravilno raspoređenih po konstrukciji. Odgovor konstrukcije se meri sa pravilno raspoređenih l senzora,

Umesto poznate diferencijalne jednačine drugog reda

$$\mathbf{M}\ddot{\mathbf{w}}(t) + \mathbf{D}\dot{\mathbf{w}}(t) + \mathbf{S}\mathbf{w}(t) = \mathbf{f}(t) \quad (1)$$

dinamičko ponašanje konstrukcije može se opisati pomoću modela *prostornog stanja*:

$$\dot{\mathbf{x}}(t) = \bar{\mathbf{A}}\mathbf{x}(t) + \bar{\mathbf{B}}\mathbf{u}(t) \quad (2)$$

$$\mathbf{y}(t) = \bar{\mathbf{C}}\mathbf{x}(t) + \bar{\mathbf{D}}\mathbf{u}(t) \quad (3)$$

gde su $\mathbf{x}(t) \in \mathbb{R}^{N \times 1}$ *vektor stanja*, $\mathbf{u}(t) \in \mathbb{R}^{m \times 1}$ *ulazni vektor*, $\mathbf{y}(t) \in \mathbb{R}^{l \times 1}$ *izlazni vektor*, $\bar{\mathbf{A}} \in \mathbb{R}^{N \times N}$ *sistemska matrica*, $\bar{\mathbf{B}} \in \mathbb{R}^{N \times m}$ *kontrolna matrica*, $\bar{\mathbf{C}} \in \mathbb{R}^{l \times N}$ *matrica posmatrač*, $\bar{\mathbf{D}} \in \mathbb{R}^{l \times m}$ *direktna prenosna matrica*, a $N = 2n$, gde je n broj stepeni slobode.

U teoriji identifikacije i realizacije sistema dostupne informacije su ulaz, tj. pobuda sistema, i izlaz, tj. odgovor sistema na zadatu pobudu; pa je početno ponašanje sistema nepoznato. Matematički, glavni problem je za date eksperimentalne ulazno/izlazne podatke naći model prostornog stanja, (2),(3), minimalnih dimenzija za date ulazno/izlazne podatke, tako da ulaz i izlaz budu zadovoljeni.

Razmotra se konstrukcijski sistem sa ulaznom impulsnom pobudom i neka je $\mathbf{y}(t) = \mathbf{y}(i\Delta t)$ meren odgovor konstrukcije na impulsni ulaz

$$\begin{cases} \mathbf{u}(0) = 1 \\ \mathbf{u}(i\Delta t) = 0, \quad i \geq 1 \end{cases}$$

Odgovor je meren u jednakim vremenskim intervalima Δt koji treba da budu "veoma" mali. Zadatak je da se sračunaju sistemske matrice $(\bar{\mathbf{A}}, \bar{\mathbf{B}}, \bar{\mathbf{C}}, \bar{\mathbf{D}})$ iz jedn. (2),(3), za dato $\mathbf{y}(t_i)$, Δt i $\mathbf{u}(t_i)$. Sledeći korak bila bi ocena dinamičkih karakteristika \mathbf{S} i \mathbf{D} iz sistemskih matrica korišćenjem specijalnog algoritma, dat jedn. (3) - (10).

Zato se problem realizacije sistema može preformulisati u sledeće: za date funkcije odgovora konstrukcije na impulsno opterećenje, tj. za set parametar Markova,

$$\{\mathbf{Y}(s)\} = \begin{cases} \mathbf{D}, & s = 0 \\ \bar{\mathbf{C}}\mathbf{A}^{s-1}\mathbf{B}, & s > 0 \end{cases}$$

naći triplet $\{\bar{\mathbf{A}}, \bar{\mathbf{B}}, \bar{\mathbf{C}}\}$, nazvan *realizacijom* modela prostornog stanja (2),(3).

Standardni algoritam, baziran na metodi identifikacije podprostora, Algoritam realizacije sopstvenog sistema (ERA) je prihvaćena i široko korišćena metoda za rešavanje pomenutog problema. Jedan od najvažnijih koraka u ERA je sračunavanje Hankelove matrice /1/.

about the system characteristics, such as stiffness and damping, are extracted from experimental input/output data. The goal of this work is to verify this method and detect the damage position in the structure.

SUBSPACE IDENTIFICATION METHOD FOR STATE-SPACE MODELS

Let us consider the structure excited by m properly distributed actuators on the structure. The response of the structure is measured by properly distributed l sensors.

Instead by well known second order differential equation

$$\mathbf{M}\ddot{\mathbf{w}}(t) + \mathbf{D}\dot{\mathbf{w}}(t) + \mathbf{S}\mathbf{w}(t) = \mathbf{f}(t) \quad (1)$$

dynamic behaviour of the structure can be described by *state-space* model:

$$\dot{\mathbf{x}}(t) = \bar{\mathbf{A}}\mathbf{x}(t) + \bar{\mathbf{B}}\mathbf{u}(t) \quad (2)$$

$$\mathbf{y}(t) = \bar{\mathbf{C}}\mathbf{x}(t) + \bar{\mathbf{D}}\mathbf{u}(t) \quad (3)$$

where $\mathbf{x}(t) \in \mathbb{R}^{N \times 1}$ is *state vector*, $\mathbf{u}(t) \in \mathbb{R}^{m \times 1}$ is *input vector*, $\mathbf{y}(t) \in \mathbb{R}^{l \times 1}$ is *output vector*, $\bar{\mathbf{A}} \in \mathbb{R}^{N \times N}$ is *system matrix*, $\bar{\mathbf{B}} \in \mathbb{R}^{N \times m}$ is *control matrix*, $\bar{\mathbf{C}} \in \mathbb{R}^{l \times N}$ is *observer matrix*, $\bar{\mathbf{D}} \in \mathbb{R}^{l \times m}$ is *direct transmission matrix* and $N = 2n$, where n is the number of degrees of freedom.

In the theory of the system identification and realisation the available informations are input, i.e., system excitation, and output, i.e., the system response on the given excitation; hence initial behavior of the system is unknown. Mathematically, the main problem is to find a state-space model, (2),(3), of minimal dimensions for the given input/output data, so that input and output are satisfied.

Let us consider the structural system with the impulse input excitation and let the $\mathbf{y}(t) = \mathbf{y}(i\Delta t)$ be the measured response of the structure on the impulse input

$$\begin{cases} \mathbf{u}(0) = 1 \\ \mathbf{u}(i\Delta t) = 0, \quad i \geq 1 \end{cases}$$

Response is measured in equidistant time steps Δt that have to be "very" small. The task is to calculate system matrices $(\bar{\mathbf{A}}, \bar{\mathbf{B}}, \bar{\mathbf{C}}, \bar{\mathbf{D}})$ from Eqs. (2),(3), for given $\mathbf{y}(t_i)$, Δt and $\mathbf{u}(t_i)$. The next step will be the evaluation of the dynamic properties \mathbf{S} and \mathbf{D} from the system matrices using a special algorithm, given by Eqs. (3) - (10).

Thus the system realisation problem may be reformulated as follows: for the given impulse response functions of the system, i. e., a set of parameters of Markov

$$\{\mathbf{Y}(s)\} = \begin{cases} \mathbf{D}, & s = 0 \\ \bar{\mathbf{C}}\mathbf{A}^{s-1}\mathbf{B}, & s > 0 \end{cases}$$

find a triplet $\{\bar{\mathbf{A}}, \bar{\mathbf{B}}, \bar{\mathbf{C}}\}$, called *realisation* of a state-space model (2),(3).

A standard algorithm, based on a subspace identification method, *Eigen-system Realisation Algorithm* (ERA) is a widely used method for solving the given problem. One of the main steps in ERA algorithm is calculating of the Hankel matrix /1/.

Iteracioni algoritam za nekompletne izlazne podatke

Potreban broj senzora zavisi od ukupnog broja stepeni slobode sistema. To znači da l (broj senzora) treba da bude jednak n (broj stepeni slobode) za jedinstvenu ocenu matrica krutosti i prigušenja. Za sistem koji ima veoma veliko n teško je staviti potreban broj senzora na konstrukciju. Šta više, u skladu sa činjenicom da dekompozicija singularnih vrednosti Hankelove matrice uvodi zavisnost od sopstvenih vrednosti sistema, povećanje broja sopstvenih vrednosti generiše sopstvene vrednosti sa višim vrednostima. To prouzrokuje izbor kraćeg vremenskog koraka Δt . Često, za sisteme sa velikim brojem stepeni slobode samo skupovi nekompletnih podataka mogu biti dostupni. Ako je $l < n$, može se koristiti iteracioni algoritam da se dobije skup nedostajućih podataka sledećom procedurom.

Može se organizovati l senzora na l lokacija na konstrukcijskom sistemu. Realni nedostajući senzora $n - l$ mogu biti zamenjeni fiktivnim sensorima koji su adekvatno raspoređeni. Ako se zna vektor stanja (odgovor) $\mathbf{x}(t)$ za ulaz $\mathbf{u}(t)$ mogu se sračunati izlazni podaci koji nedostaju. Početne vrednosti matrica krutosti i mase $\mathbf{S}_0, \mathbf{M}_0$ računaju se koristeći analizu konstrukcije za diskretizovane sisteme ili pomoću metode diskretizacije za kontinualne sisteme. Ocena početne matrice prigušenja nije lak posao. Stoga se $\mathbf{D}_0 = 0$ može smatrati početnom vrednosti, a trenutna vrednost \mathbf{D} i \mathbf{S} može biti sračunata upotrebom algoritma.

$$\bar{\mathbf{A}}_{\alpha} = \begin{bmatrix} \mathbf{0} & \mathbf{I}_n \\ -\mathbf{M}_0^{-1}\mathbf{S}_{\alpha} & -\mathbf{M}_0^{-1}\mathbf{D}_{\alpha} \end{bmatrix} \quad (3)$$

$$\bar{\mathbf{B}}_{\alpha} = \begin{bmatrix} \mathbf{0} \\ \mathbf{M}_0^{-1}\mathbf{G}_{\alpha} \end{bmatrix} \quad (4)$$

$$\tilde{\mathbf{C}}_{\alpha} = [\mathbf{0} \quad \mathbf{I}_{n-l}] \left([\hat{\mathbf{C}}_d \quad \hat{\mathbf{C}}_v] - \hat{\mathbf{C}}_a \mathbf{M}_0^{-1} [\mathbf{S}_{\alpha} \quad \mathbf{D}_{\alpha}] \right) \quad (5)$$

$$\dot{\mathbf{x}}_{\alpha}(t) = \bar{\mathbf{A}}_{\alpha} \mathbf{x}_{\alpha}(t) + \bar{\mathbf{B}}_{\alpha} \mathbf{u}(t) \quad (6)$$

$$\tilde{\mathbf{y}}_{\alpha}(t) = \tilde{\mathbf{C}}_{\alpha} \mathbf{x}_{\alpha}(t) + \tilde{\mathbf{D}}_{\alpha} \mathbf{u}(t) \quad (7)$$

$$\hat{\mathbf{y}}_{\alpha}(t) = \begin{bmatrix} \mathbf{y}(t) \\ \tilde{\mathbf{y}}_{\alpha}(t) \end{bmatrix} \quad (8)$$

$$\left(\bar{\mathbf{A}}'_{\alpha+1}, \bar{\mathbf{B}}'_{\alpha+1}, \bar{\mathbf{C}}'_{\alpha+1} \right) = \text{ERA}(\hat{\mathbf{y}}_{\alpha}(t)) \quad (9)$$

$$\left(\mathbf{S}_{\alpha+1}, \mathbf{D}_{\alpha+1}, \mathbf{G}_{\alpha+1} \right) = \Phi(\bar{\mathbf{A}}'_{\alpha+1}, \bar{\mathbf{B}}'_{\alpha+1}, \bar{\mathbf{C}}'_{\alpha+1}) \quad (10)$$

Postupak se obustavlja kada algoritam obezbedi zadovoljavajuće vrednosti za matrice \mathbf{S} , \mathbf{D} i \mathbf{G} . U predhodnim jednačinama $\bar{\mathbf{C}} \in \mathbb{R}^{l \times n}$ je matrica posmatrač merenih podataka, $\tilde{\mathbf{C}} \in \mathbb{R}^{(n-l) \times n}$ - matrica posmatrač podataka koji nedostaju, $\bar{\mathbf{D}} \in \mathbb{R}^{l \times n}$ - direktna prenosna matrica merenih podataka, $\tilde{\mathbf{D}} \in \mathbb{R}^{(n-l) \times n}$ - direktna prenosna matrica podataka koji nedostaju, $\mathbf{0}$ nulta matrica dimenzija $l \times (n-l)$, $\mathbf{y}(t) \in \mathbb{R}^{l \times 1}$ - meren odgovor konstrukcije (mereni izlaz), $\tilde{\mathbf{y}}(t) \in \mathbb{R}^{(n-l) \times 1}$ - odgovor konstrukcije koji nedostaje, $\hat{\mathbf{y}}(t) \in \mathbb{R}^{n \times 1}$ - kompletan odgovor konstrukcije.

Iteration algorithm for incomplete output data

The number of sensors depends on the total number of system degrees of freedom. That means that l (number of sensors) has to be equal to n (number of degrees of freedom) for unique evaluating the stiffness and damping matrices. For the system which has a very large n it is difficult to put necessary number of sensors on the structure. Moreover, due to the fact that the singular value decomposition of the Hankel matrix involves the dependence on the system eigenvalues, an increased number of eigenvalues generates eigenvalues with higher values. That causes the choice of shorter time steps Δt . Usually, for the system with a large number of degree of freedom only a set of incomplete data may be available. If $l < n$, an iteration algorithm can be used to provide a set of lacking data using following procedure.

One can arrange l sensors at l locations in structural system. The $n - l$ missing real sensors can be replaced with the fictive sensors which are properly disposed. If the state vector (response) $\mathbf{x}(t)$ for input $\mathbf{u}(t)$ is known, one can gain the missing output data. The initial values for stiffness and mass matrices $\mathbf{S}_0, \mathbf{M}_0$ are calculated using structural analysis for discretized system or from discretization methods for continuous systems. The evaluation of initial damping matrix is a difficult task. Hence $\mathbf{D}_0 = 0$ can be used as initial value and the current values of \mathbf{D} and \mathbf{S} can be computed through the algorithm.

$$\bar{\mathbf{A}}_{\alpha} = \begin{bmatrix} \mathbf{0} & \mathbf{I}_n \\ -\mathbf{M}_0^{-1}\mathbf{S}_{\alpha} & -\mathbf{M}_0^{-1}\mathbf{D}_{\alpha} \end{bmatrix} \quad (3)$$

$$\bar{\mathbf{B}}_{\alpha} = \begin{bmatrix} \mathbf{0} \\ \mathbf{M}_0^{-1}\mathbf{G}_{\alpha} \end{bmatrix} \quad (4)$$

$$\tilde{\mathbf{C}}_{\alpha} = [\mathbf{0} \quad \mathbf{I}_{n-l}] \left([\hat{\mathbf{C}}_d \quad \hat{\mathbf{C}}_v] - \hat{\mathbf{C}}_a \mathbf{M}_0^{-1} [\mathbf{S}_{\alpha} \quad \mathbf{D}_{\alpha}] \right) \quad (5)$$

$$\dot{\mathbf{x}}_{\alpha}(t) = \bar{\mathbf{A}}_{\alpha} \mathbf{x}_{\alpha}(t) + \bar{\mathbf{B}}_{\alpha} \mathbf{u}(t) \quad (6)$$

$$\tilde{\mathbf{y}}_{\alpha}(t) = \tilde{\mathbf{C}}_{\alpha} \mathbf{x}_{\alpha}(t) + \tilde{\mathbf{D}}_{\alpha} \mathbf{u}(t) \quad (7)$$

$$\hat{\mathbf{y}}_{\alpha}(t) = \begin{bmatrix} \mathbf{y}(t) \\ \tilde{\mathbf{y}}_{\alpha}(t) \end{bmatrix} \quad (8)$$

$$\left(\bar{\mathbf{A}}'_{\alpha+1}, \bar{\mathbf{B}}'_{\alpha+1}, \bar{\mathbf{C}}'_{\alpha+1} \right) = \text{ERA}(\hat{\mathbf{y}}_{\alpha}(t)) \quad (9)$$

$$\left(\mathbf{S}_{\alpha+1}, \mathbf{D}_{\alpha+1}, \mathbf{G}_{\alpha+1} \right) = \Phi(\bar{\mathbf{A}}'_{\alpha+1}, \bar{\mathbf{B}}'_{\alpha+1}, \bar{\mathbf{C}}'_{\alpha+1}) \quad (10)$$

The procedure stops when the algorithm provides satisfactory values for matrices \mathbf{S} , \mathbf{D} and \mathbf{G} . In the previous equations $\bar{\mathbf{C}} \in \mathbb{R}^{l \times n}$ is the observer matrix for the measured data, $\tilde{\mathbf{C}} \in \mathbb{R}^{(n-l) \times n}$ - observer matrix for the missing data, $\bar{\mathbf{D}} \in \mathbb{R}^{l \times n}$ - direct transmission matrix for the measured data, $\tilde{\mathbf{D}} \in \mathbb{R}^{(n-l) \times n}$ - direct transmission matrix for the missing data, $\mathbf{0}$ is zero matrix of size $l \times (n-l)$, $\mathbf{y}(t) \in \mathbb{R}^{l \times 1}$ - measured response of the structure (measured output), $\tilde{\mathbf{y}}(t) \in \mathbb{R}^{(n-l) \times 1}$ - the missing response of structure, $\hat{\mathbf{y}}(t) \in \mathbb{R}^{n \times 1}$ - complete structure response.

EKSPERIMENTALNI POSTUPAK

U okviru provere metode zasnovane na teorijskim pretpostavkama prema jedn. (1), izvedeno je nekoliko eksperimenata. Dva čelična nosača - grede (profil IPB 100), oba 4 m dužine, sa različitim načinima oslanjanja, (sl. 1. i 2.), su ispitana u laboratoriji /2/. Odgovor konstrukcije (ubrzanje) na zadato impulsno opterećenje zapisivan je sa 16 senzora raspoređenih na istom rastojanju po gornjoj strani nosača.

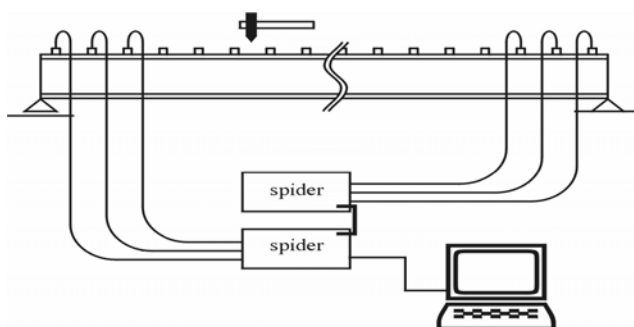

Slika 1. Šematski prikaz korišćene opreme
Figure 1. Schematic presentation of used equipment.

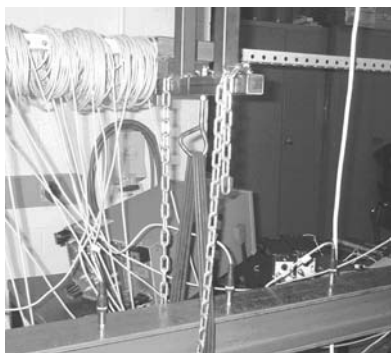

Slika 3. Oslonac - gređa I
Figure 3. Support - beam I.

EXPERIMENTAL PROCEDURE

In the scope of testing this method based on theoretical prepositions from Eq. (1), several experiments have been performed. Two steel bars - beams (IPB 100 profile), both of 4 m in length, with different way of supporting, (Fig. 1 and 2) were tested in laboratory /2/. The response of the structure (acceleration) to impulse load was recorded with 16 sensors positioned equidistantly on the upper side of the bar.

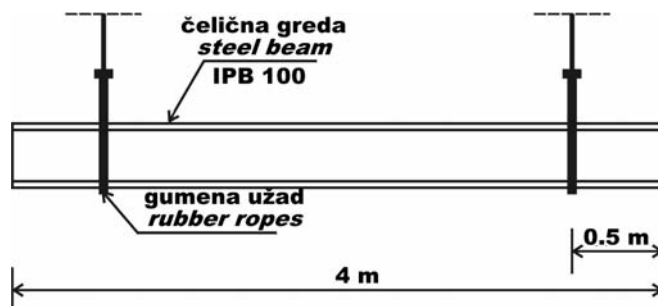

Slika 2. Šematski prikaz konstrukcije - gređa I
Figure 2. Schematic presentation of the structure - beam I.



Slika 4. Oslonac - gređa II
Figure 4. Support - beam II.

Detalji o opterećenju i eksperimentalni rezultati

Pobuda nosača je bilo impulsno opterećenje zadato čekićem. Provereno je da je trajanje delovanja sile bilo zaista "kratko" - kraće od 0.2 ms. Ovo potvrđuje da se sila delovanja može tretirati kao impulsno opterećenje; zaista, frekvencija je bila 4800 Hz, tj vremenski korak je bio ≈ 0.2 ms. U svakom slučaju dužina merenja odgovora konstrukcije je bila 3 sec. Ukupan skup podataka je obuhvatio informacije sa 16 položaja na nosaču. Podaci su zapamćeni na takav način da se mogu koristiti kao ulazni podaci za program, napisan u Scilab, kao i za već gotove softvere bazirane na konačnim elementima.

Tokom merenja je prikupljen veliki broj podataka, ali je samo nekoliko karakterističnih slučajeva izabrano za prikazivanje u ovom odeljku. U prva četiri dijagrama (sl. 5 -8.) potpun skup podataka jednog merenja je prikazan za jedan karakterističan senzor. Instrument nije bio podešen na okidanje, tj. merenje ne počinje kada je opterećenje zadato. To je urađeno kako bi se uočili početni šumovi, kao i šumovi nakon prestanka vibracije gređe. Prva tri dijagrama predstavljaju odgovore gređe I.

Load details and experimental results

The excitation of the bars was an impulse load applied by hammer. It was checked that the duration of acting force was really "short" - less than 0.2 ms. This confirmed that acting force can be considered as an impulse load; indeed, the frequency was 4800 Hz, i.e., the time step was ≈ 0.2 ms. In each case the duration of the structure response measuring was 3 sec. The whole set of data was supplying information from 16 locations of the beam. Data were stored in such a way that they can be used as input data for the program, written in Scilab, as well as for a finite element program.

Although a large amount of data was collected, only few typical cases have been selected for presentation in this section. In the first four diagrams (Figs. 5.-8.) the whole sets of data of one measurement for one characteristic sensor are shown. Instrument was not set to trigger, i.e., measurement does not start when load is applied. This is done in order to detect initial noises as well as the noises after finishing the beam I vibration. First three diagrams represent the response of the beam I.

Zbog elastičnih oslonaca (što je izazvalo i kretanje krutog tela) uticaj prigušenja je manji nego kod grede II, gde su oslonci krući i postavljeni na krajevima. Stoga je uticaj prigušenja vrlo jak, sl. 8. Zbog popustljivih oslonaca grede I, može se reći da kretanje krutog tela igra značajnu ulogu. Ovo dokazuje da je greda II prihvatljiviji statički sistem u problemu koji je razmatran.

Na poslednjem dijagramu (sl. 9) prikazani su podaci sakupljeni iz različitih merenja. Zbog toga su oni odsečeni u momentu kada se pojavljuje odgovor konstrukcije i vremenska osa je uzeta da na tom mestu počinje od nule. Frekvencija broja merenja je u svakom merenju bila ista, stoga je predhodni postupak bio dozvoljen. Ovaj dijagram pokazuje odgovore konstrukcija na istom mestu ali za tri različita slučaja. Prvi, nazvan **slobodan**, je ustvari osnovni sistem bez dodatne mase stega koja će kasnije simulirati oštećenje; drugi, nazvan **neoštećen** je slučaj gde je stega postavljena na konstrukciju, ali je ona predstavljala samo dodatnu masu osnovnoj konstrukciji, jer je bila jako stegnuta i talas je mogao da prođe kroz gredu bez kašnjenja; i treći, **oštećen**, u kome stega nije bila jako utegnuta, pa je konstrukcija bila na tom delu oštećena, u poređenju sa predhodna dva slučaja. Upoređivanjem rezultata može se zaključiti da je ovakav način simulacije oštećenja primenljiv budući da očigledno daje teorijski očekivane razlike u izlaznim podacima.

Na ovom dijagramu se jasno može videti kašnjenje odgovora sistema u slučaju *neoštećene* i *oštećene* grede u poređenju sa *slobodnom* gredom. Veća masa u prva dva slučaja prouzrokuje veću inerciju, pa odgovor konstrukcije kasni. Krutost grede u *neoštećenom* slučaju je veća u odnosu na *oštećeni* slučaj. To izaziva višu frekvencu oscilovanja grede (manji period oscilovanja). Amplitude se ne mogu porediti budući da je u svakom ispitivanju primenjen proizvoljan intenzitet sile. Amplitude ubrzanja su u zavisnosti od opterećenja, stoga su različiti u svakom merenju, ali oblik dijagrama se može upoređivati.

NUMERIČKA PROCEDURA

Neophodan broj senzora mora biti jednak ukupnom broju stepeni slobode. Ovde je greda posmatrana kao diskretizovana konstrukcija sa konačnim brojem stepeni slobode sa 8 konstitutivnih elemenata (tj. 9 čvorova) i sa dozvoljena dva stepena slobode u svakom čvoru: poprečna deformacija i ugao savijanja. Iako su u dva čvora na osloncima poprečne deformacije sprečene, ukupan broj stepeni slobode je izabran da bude 16. Dakle, broj senzora, 16, je bio jednak broju stepeni slobode (16). Stoga teorijski rezultati matrica krutosti i prigušenja **S** i **D** treba da su jedinstveni. Za skup nekompletnih podataka je ideja da se zanemare mereni rezultati nekih senzora i da se smatraju fiktivnim, a njihovi podaci treba da budu sračunati kroz algoritam, (3) - (10). Dalje, rezultati dobijeni iz algoritma se mogu uporediti sa merenim vrednostima istih senzora. Ovo poređenje može dati informaciju o važenju algoritma.

Program je pisan u Scilab-u, besplatnom MatLab^R klonu. Scilab je moćno interaktivno programsko okruženje otvorenog koda koje umnogome olakšava zadatke numeričkih izračunavanja i analize podataka.

Due to the elastic supports (affecting also motion of solid body) the effect of damping is less strong than in case of the beam II, where the supports were stiffer and located at the edges. Then, damping effect is very strong, Fig. 8. Due to the soft supports in bar I, it can be said that the rigid body motion played an important role. This showed that beam II is more convenient static for considered problem.

On the last diagram (Fig. 9) data were collected from different measurements. Therefore, they were rejected from the moment when the response of structure occurred; the time axis was chosen to start from zero at that point. The sample frequency in each measurement was the same, so, performed procedure was allowed. This diagram presents the response of the structure at the same position, but for three different cases. First one, called **free**, is base system without additional mass of clamp which will later simulate damage; second, named **undamaged** is the case where a clamp was placed on the structure, but it presented only an additional mass to base structure, since it was strongly tightened and the wave could pass through the beam without delay; and third, **damaged**, where clamp was not tightened strongly, hence the structure was damaged in the clamped part, compared to the foregoing two cases. Comparing the results it can be concluded that this kind of damage simulation can be applied because it evidently causes the expected differences in output data.

On that diagram the delay of the response of the system can be seen in the case of *undamaged* and *damaged* beam compared to the *free* beam. The greater mass in the first two cases produces greater inertia and structure answer is delayed. The stiffness of the beam in *undamaged* case is greater compared to *damaged* case. That causes the greater frequency of beam oscillation (the smaller oscillation period). The amplitudes cannot be compared because in each test random intensity force was applied. The acceleration amplitudes depend on load and hence different in each measurement, but the diagram shapes are comparable.

NUMERICAL PROCEDURE

The necessary number of sensors has to be equal to the total number of degree of freedom (DOF). Hence the beam was considered as a finite DOF discretized structure with 8 constitutive elements (i.e., 9 nodes) and in each node 2 DOF were allowed: lateral deformation and bending angle. Although in two nodes at supports lateral deformation is restrained the total number of DOF was accepted to be 16. So, the number of sensors, 16, was equal to the number of DOF, 16. Hence the theoretical result of the stiffness and damping matrices **S** and **D** should be unique. For the set of incomplete data the idea was to ignore measured results of some of sensors which could be considered as fictive, and their data have to be calculated through algorithm (3) - (10). Further, the results from algorithm could be compared with measured values for the same sensors. This comparison could give the information about validity of the algorithm.

The program was written in Scilab, a free MatLab^R clone. Scilab is a powerful interactive open source programming environment that greatly facilitates the task of numerical computations and data analysis.

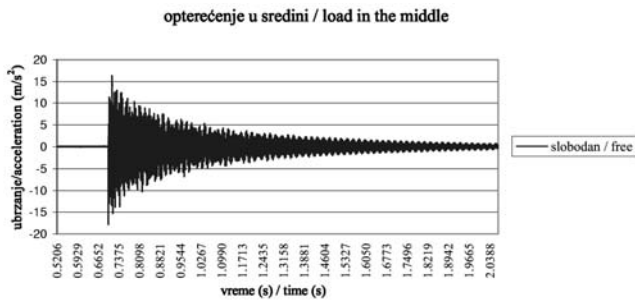

Slika 5. Odgovor grede I u *slobodnom* slučaju
Figure 5. Response of the beam I in free case.

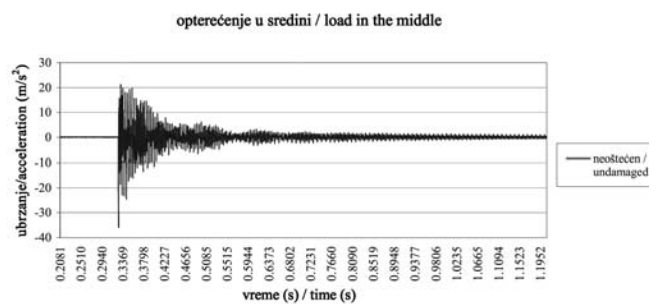

Slika 6. Odgovor grede I u *neoštećenom* slučaju
Figure 6. Response of the beam I in undamaged case.

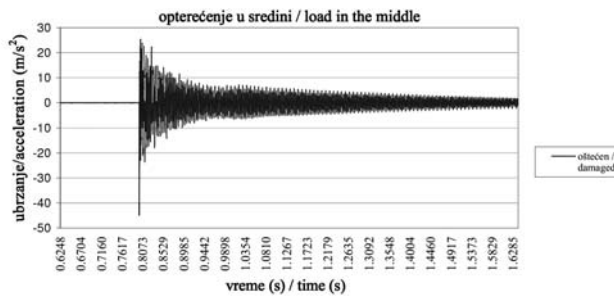

Slika 7. Odgovor grede I u *oštećenom* slučaju
Figure 7. Response of the beam I in damaged case.

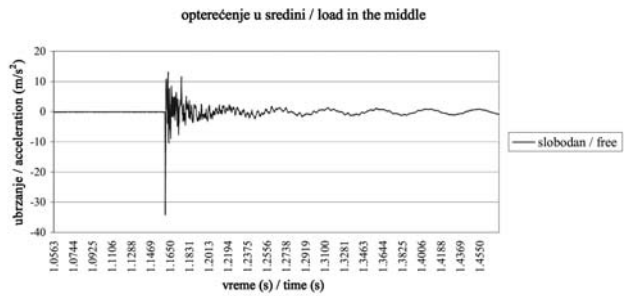

Slika 8. Odgovor grede II u *slobodnom* slučaju
Figure 8. Response of the beam II in free case.

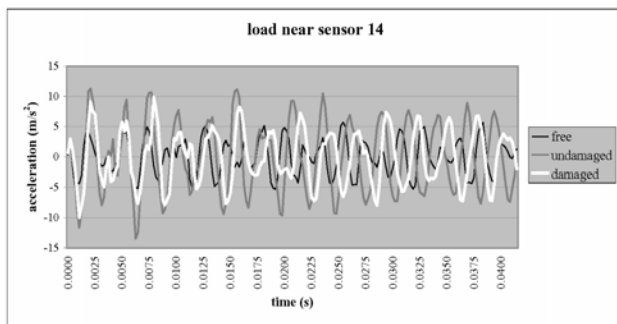

Slika 9. Odgovor grede I sa i bez simulacije oštećenja
Figure 9. Response of the beam I with and without damage simulation.

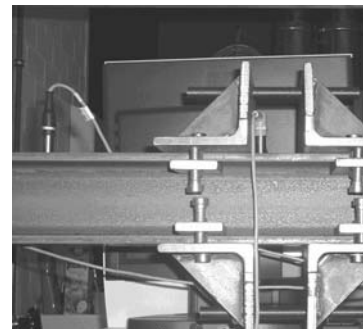

Slika 10. Simulacija oštećenja
Figure 10. Simulation of the damage.

Scilab je dizajniran za inženjersku i naučnu primenu. Scilab je pogodan za korišćenje kao i MatLab^R. Brojne numeričke operacije, crtanje dijagrama, i druge operacije. su programirani i spremni za upotrebu. Realizacija prostornog stanja je takođe jedan od algoritama koji su uneti u paket (routine imrep2ss). Program je napisan tako da izvršava kompletno rešavanje problema identifikacije sistema. Može se videti da numerička procedura, iako spremna za korišćenje, blokira na izlazu iz metode podprostora. Glavni razlog ovakvog ponašanja je činjenica da metoda još uvek nije razvijena za upotrebu automatskog izvršenja. I zaista, za svaki pojedinačni skup podataka, pravilan podskup podataka koji će biti korišćen u metodi podprostora mora biti manuelno odabran. U ovu svrhu podskup podataka mora biti analiziran kroz brye Furijeove transformacije da bi se videlo da li su sopstvene vrednosti uporedive sa računski dobijenim. Takođe, vremenski korak prilikom merenja igra istaknutu ulogu u kvalitetu identifikacije podprostora.

Scilab has been designed for engineering and scientific applications. Scilab is a user-friendly environment such as MatLab^R. Numerous numerical operations, plots, and other operations are programmed and ready to be used. A state space realization is also one of the algorithms that are implemented in this software package (routine imrep2ss). The programs have been written to make the full solution of the system identification problem. It can be seen that the numerical procedure, though ready for use, stuck at the output of the subspace method. The main reason for this behaviour is the fact that this method is still not developed for use of automatic proceeding. Indeed, for each single set of data, the right subset of data to be used in the subspace method has to be selected by hand. For this purpose the subset data have to be analyzed by Fast Fourier Transformation in order to see if the eigenvalues are comparable to eigenvalues of obtained numerically. Also, the time step during measurement plays an eminent role for the quality of subspace identification.

ZAKLJUČAK

Ovaj rad pokazuje da je metoda identifikacije podprosto-
ra moguće sredstvo za automatsku identifikaciju sistemskih
parametara koja još uvek nije sasvim proučena. Dalja
istraživanja i razvoj u ovoj oblasti biće predmet daljeg rada,
posebno u prevazilaženju uočenih neprikladnosti. Takođe,
treba razmotriti da li je linerno opisivanje sistema dovoljno
za otkrivanje oštećenja ili treba koristiti usavršenije metode
koje će uzeti u obzir i nelinearne efekte. Šumovi i drugi
nepoželjni uticaji, koji mogu značajno izmeniti ulazne po-
datke, moraju posebno biti uzeti u obzir.

LITERATURA – REFERENCES

1. Xiao H., Bruhns O. T., Waller H. and Meyers A.: *An input/output-based procedure for fully evaluating and monitoring dynamic properties of structural systems via subspace identification method*, Journal of Sound and Vibration, 264/4, pp. 601-623, 2001.
2. Trajković M., *Investigation on dynamic properties of linear systems/ Ispitivanje dinamičkih karakteristika linearnih sistema*, Edition Academia, Andrejević Endowment: Belgrade 2004.
3. Trajković M., *Monitoring dynamic properties of linear systems*, Institute of Technical Mechanics, Faculty of Civil Engineering, University of Bochum, 2002.
4. Lim Ryoung K., Phan Minh Q. and Longman Richard W.: *State-Space System Identification with Identified Hankel Matrix*, Department of Mechanical and Aerospace Engineering, Technical Report No.3045, Princeton University, Princeton, NJ., 1998.
5. Peeters B., Wahab M. Abdel, De Roeck G., De Visscher J., De Wilde W. P., Ndambi J.-M. and Vantomme J: *Evaluation of structural damage by dynamic system identification.*, Proceedings of ISMA 21, Leuven, Belgium, pp. 1349-1361, 1996.

CONCLUSION

This paper shows that subspace identification algorithm is a possible tool for the automatic identification of system parameters that is not yet completely studied. Further investigation and development in this field will be the topic of the future work, especially in overcoming the noticed inadequacies. Also, linear system description should be considered if sufficient for detection of damage. Alternately, more sophisticated methods should be used to account for nonlinear effects. Noise and other disturbing effects that may substantially change input data should be particularly taken into account.



Časopis Društva za integritet i vek konstrukcija – INTEGRITET I VEK KONSTRUKCIJA
Journal of the Society for Structural Integrity and Life – STRUCTURAL INTEGRITY AND LIFE

<http://divk.org.yu/ivk>

Cenovnik oglasnog prostora u časopisu IVK za jednu godinu
Advertising fees for one subscription year (per volume)

Kvalitet*Quality	Dimenzije*Dimensions (mm)	Cene u din.	EUR
Kolor*Colour	• obe strane*two pages 2x A4	30.000	700
	• strana*page A4/1	20.000	450
Dostava materijala: CD (Adobe Photoshop/CorelDRAW) Print material: CD (Adobe Photoshop/CorelDRAW)			
Crno-beli*Black/White	• strana*page A4/1	10.000	250
	• 1/2 str A4*1/2 page A4(18x12)	7.000	150
Dostava materijala: CD (Adobe Photoshop/CorelDRAW) Print material: CD (Adobe Photoshop/CorelDRAW)			

Pomažući članovi DIVK imaju popust od 40% navedenih cena.
DIVK supporting members are entitled to a 40% discount on upper prices.