

---

# O viskoplastičnim polikristalima prividno inkrementalnog tipa

Milan V. Mićunović

---

Prezentacija na Mašinskom fakultetu u Beogradu  
DIVK, 17. februar 2011.

# 1. Deo

mali uvod



# 1. On diverse speed regimes

All the contemporary calculations of structures exposed to impact, earthquake, wind and severe dynamic excitations are made by Finite element method (FEM) codes but often with wrong material constants. Such mistakes could lead to

- Unrealistic dimensions
- Catastrophic events (like fracture of heavy structures) etc

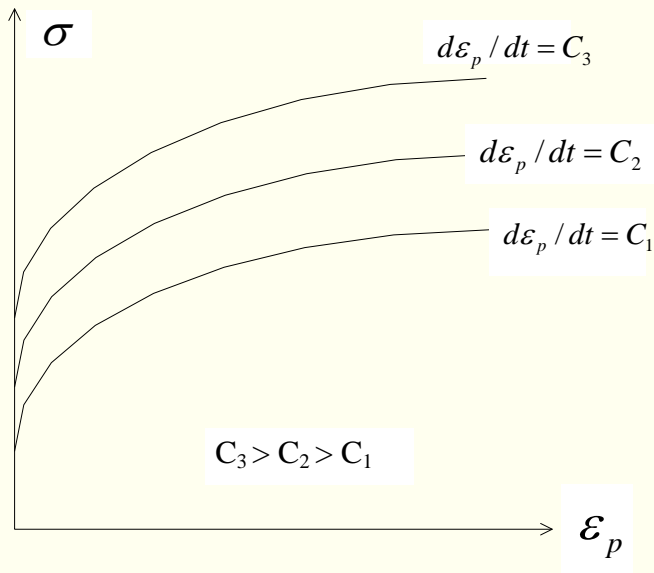

Material constants found from slow tests applied to higher stress and strain histories



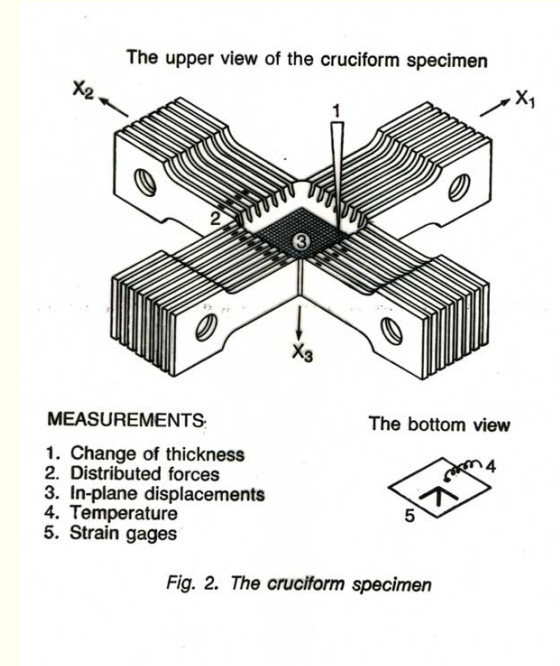
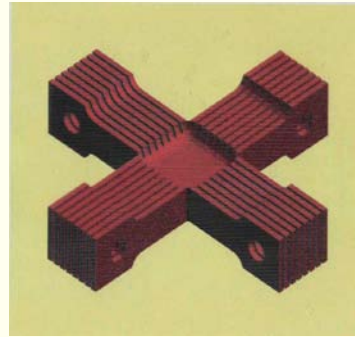
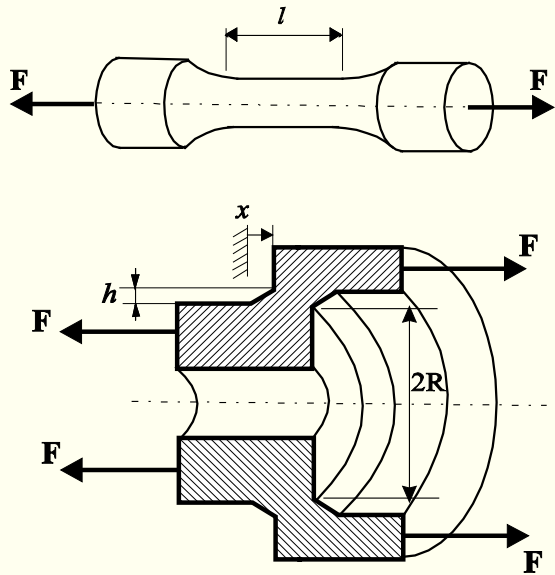
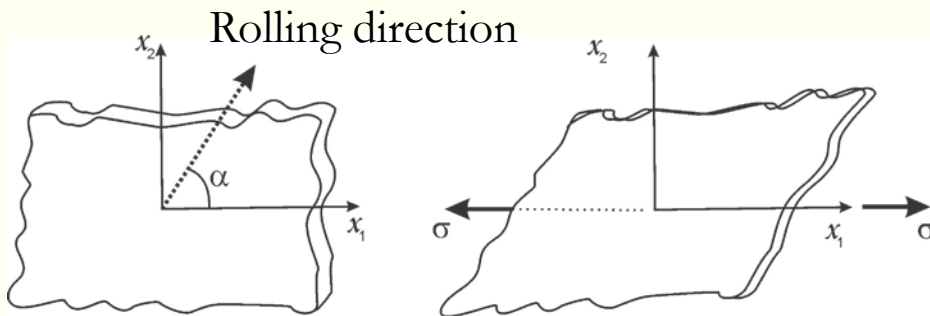
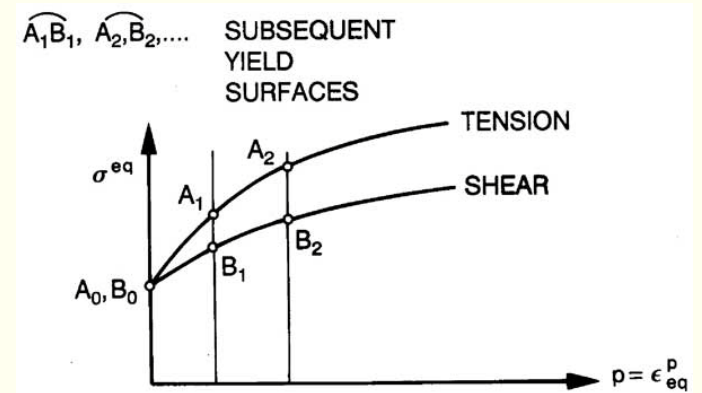
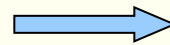
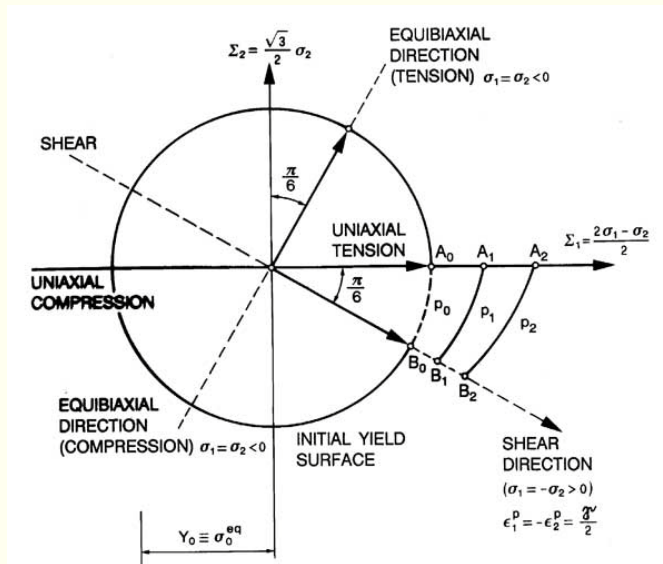

Fig. 2. The cruciform specimen

- From experimental results obtained in JRC-Ispra, Italy some viscoplastic constitutive models have been formulated and calibrated . Stress-strain histories are from static to impact. Experimental directionality is covered by tensor representation.



# Diverse testing histories



Application to sheet metal forming – Hill anisotropic yield condition inadequate



# 2. Inelastic waves by Hopkinson bar technique

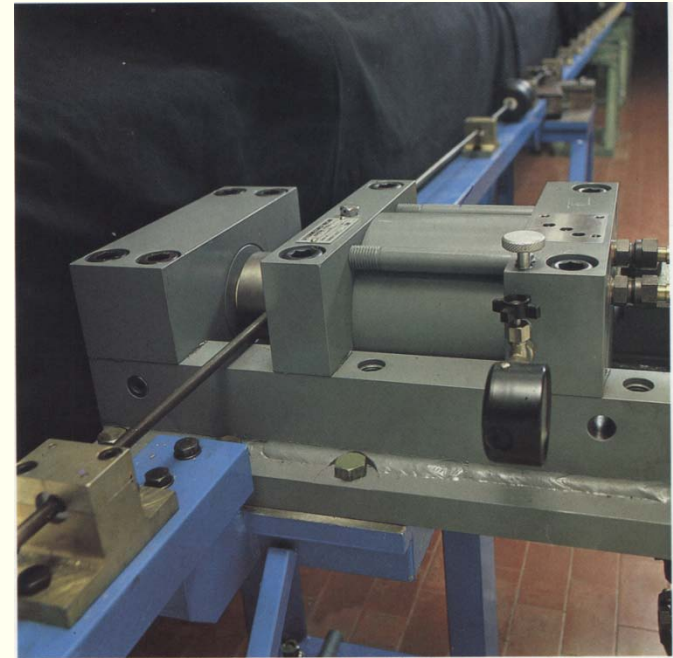
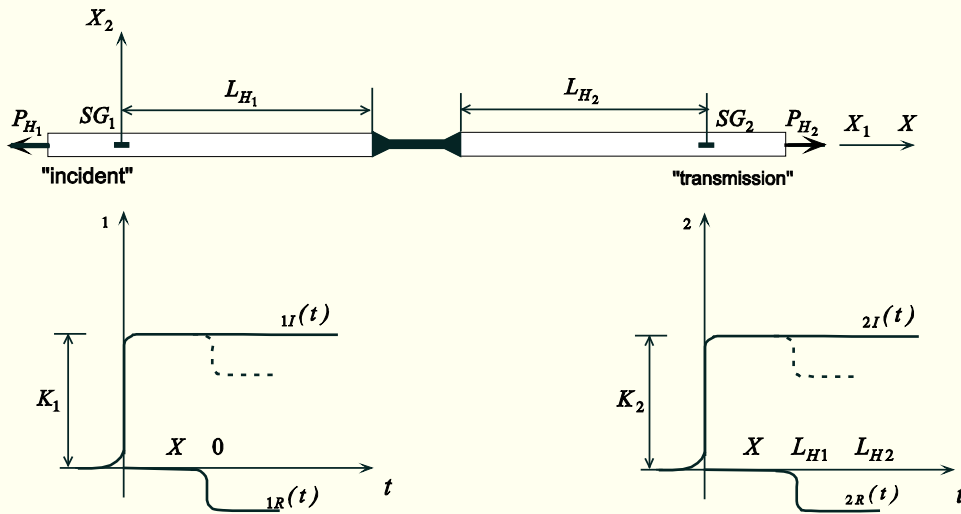

Measurement by strain gauges outside the specimen

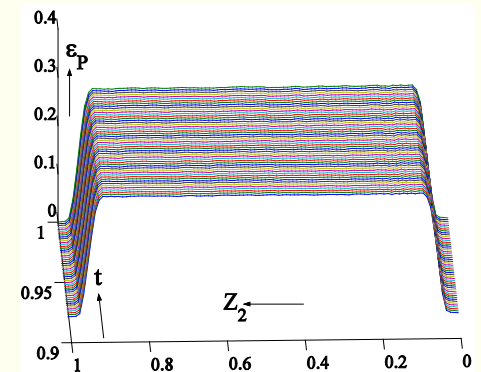
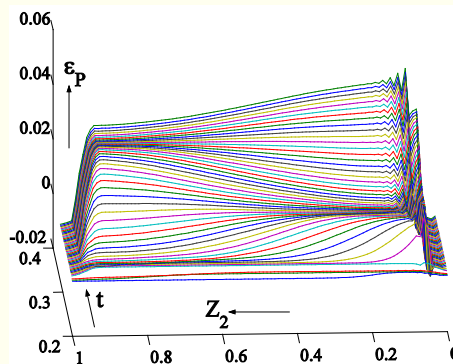
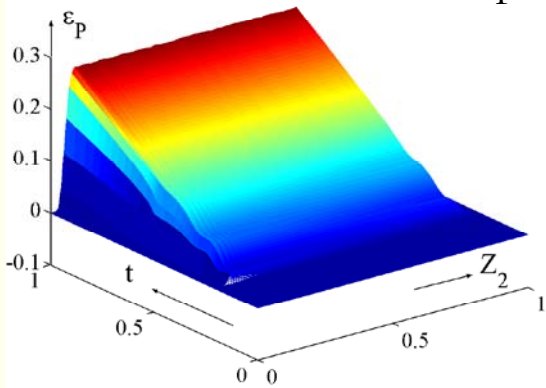

### Static, hydro and Hopkinson test results

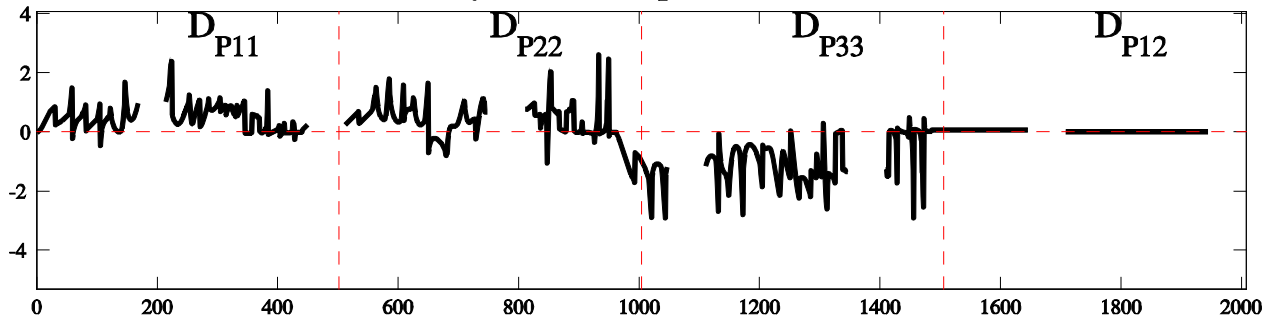

### Tensor representation linear MAM model

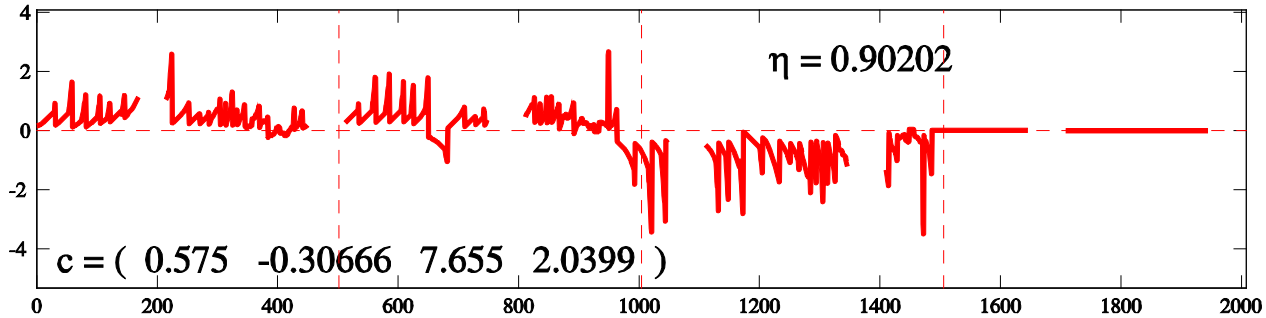

### Universal flow rule (Armstrong-Zerilli model)

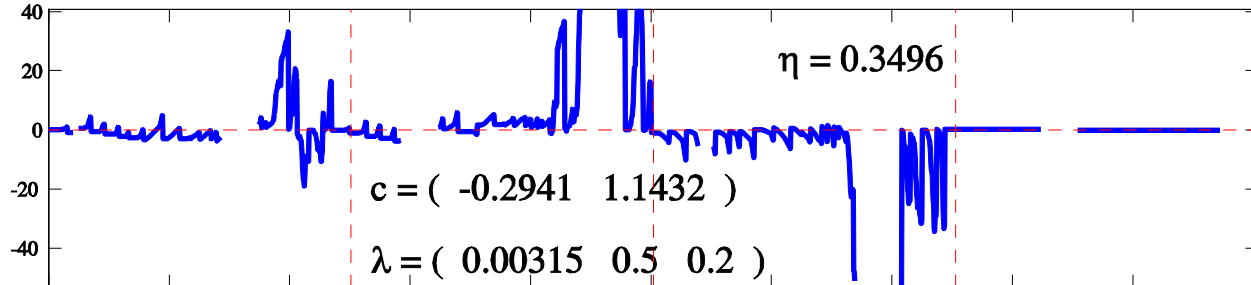

### 3. Crack growth on bimaterial anisotropic interface

IJF, 2010 (R. Nikolic, J.Djokovic, MM)

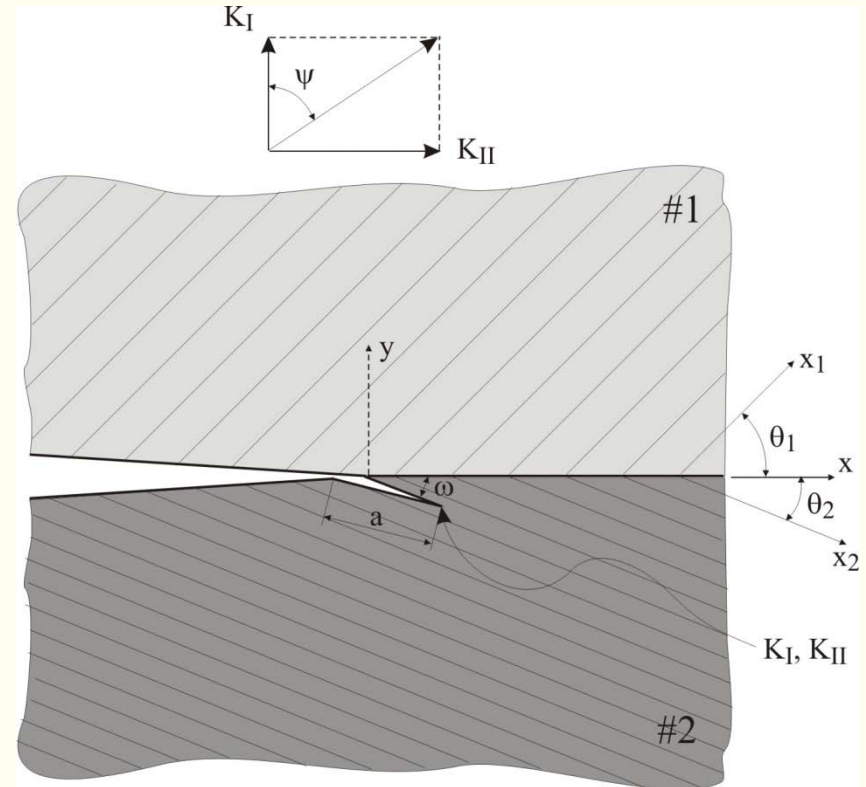
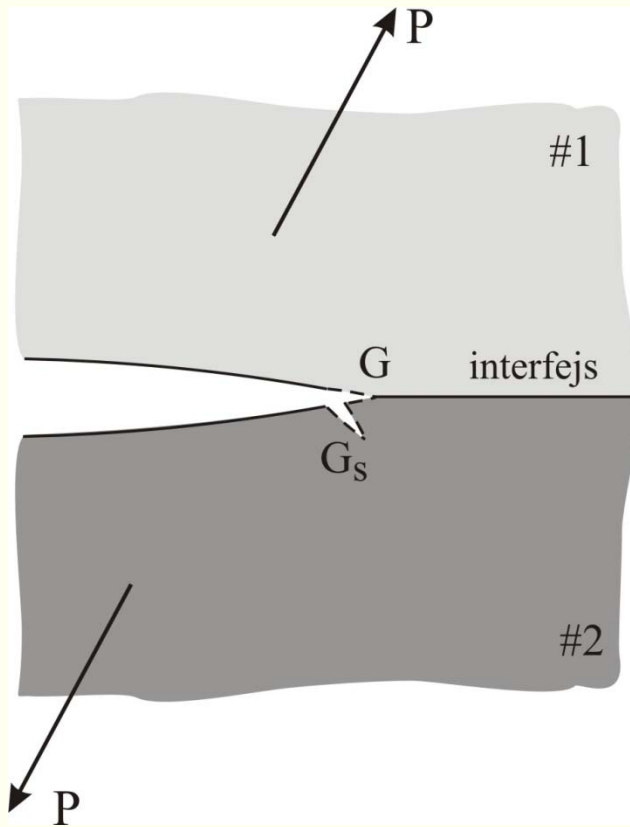

---

# O orijentaciji RVE (reprezentativnog zapreminskog elementa)



# Representative volume element size step 1 (maximal size)

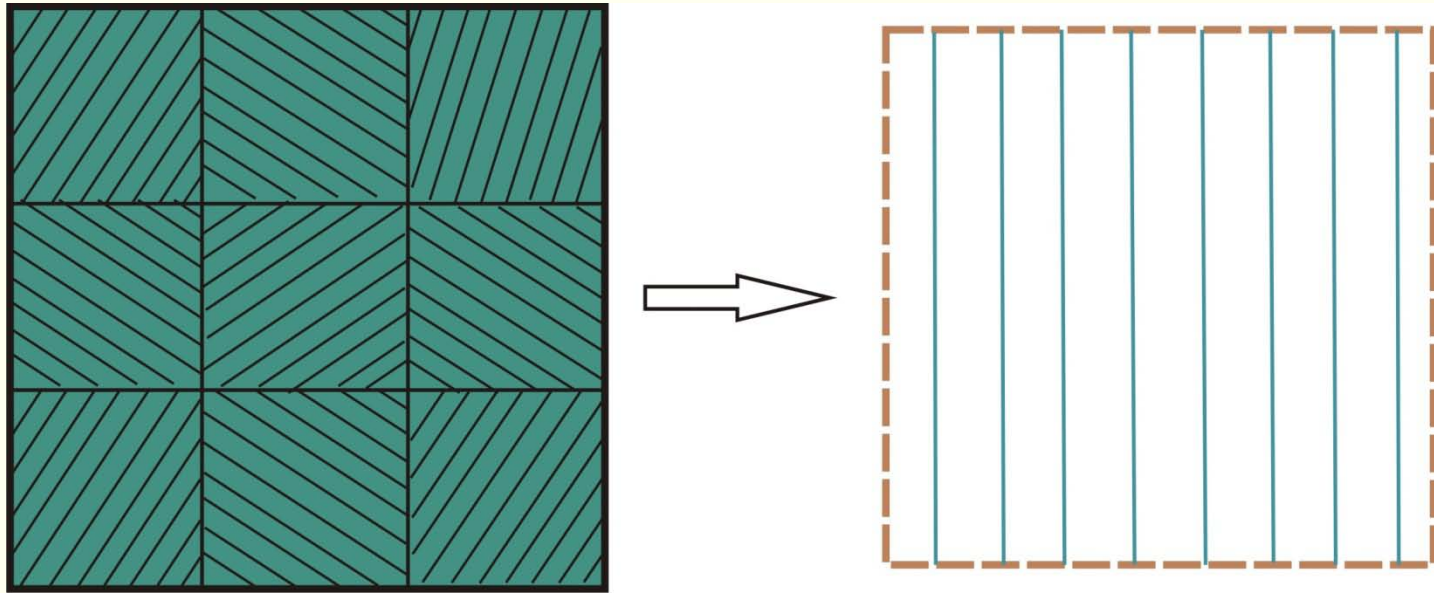

## step 2

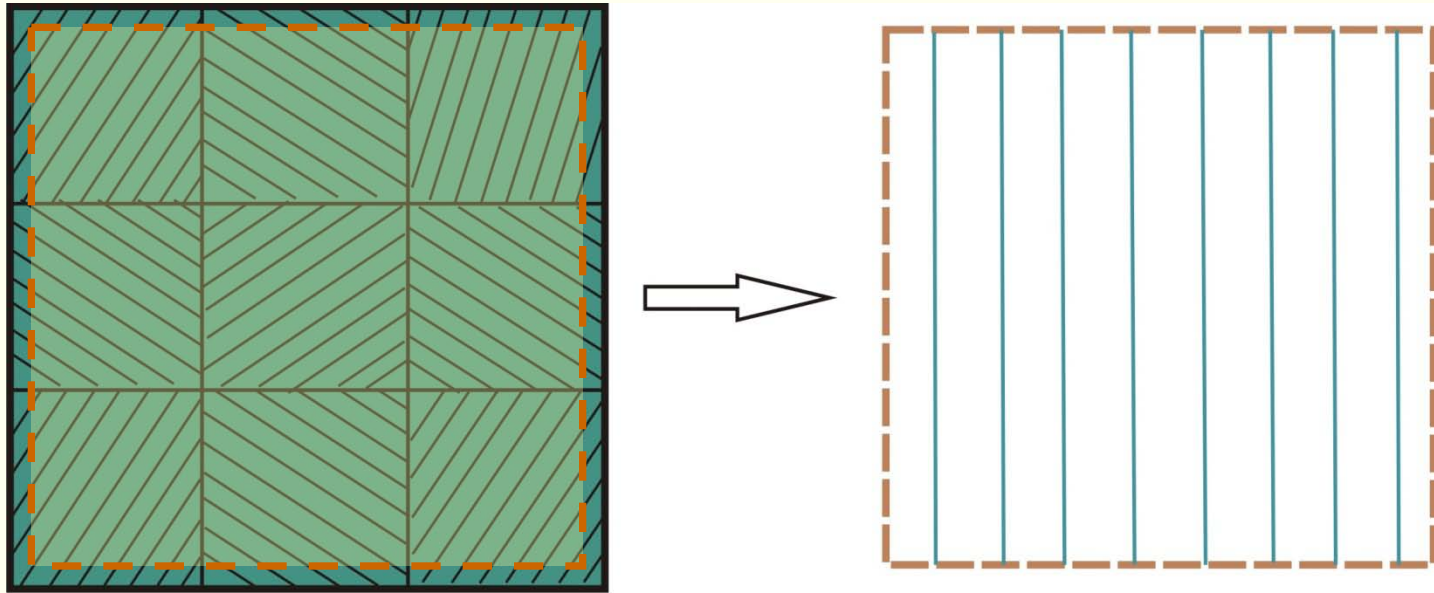

# step 3

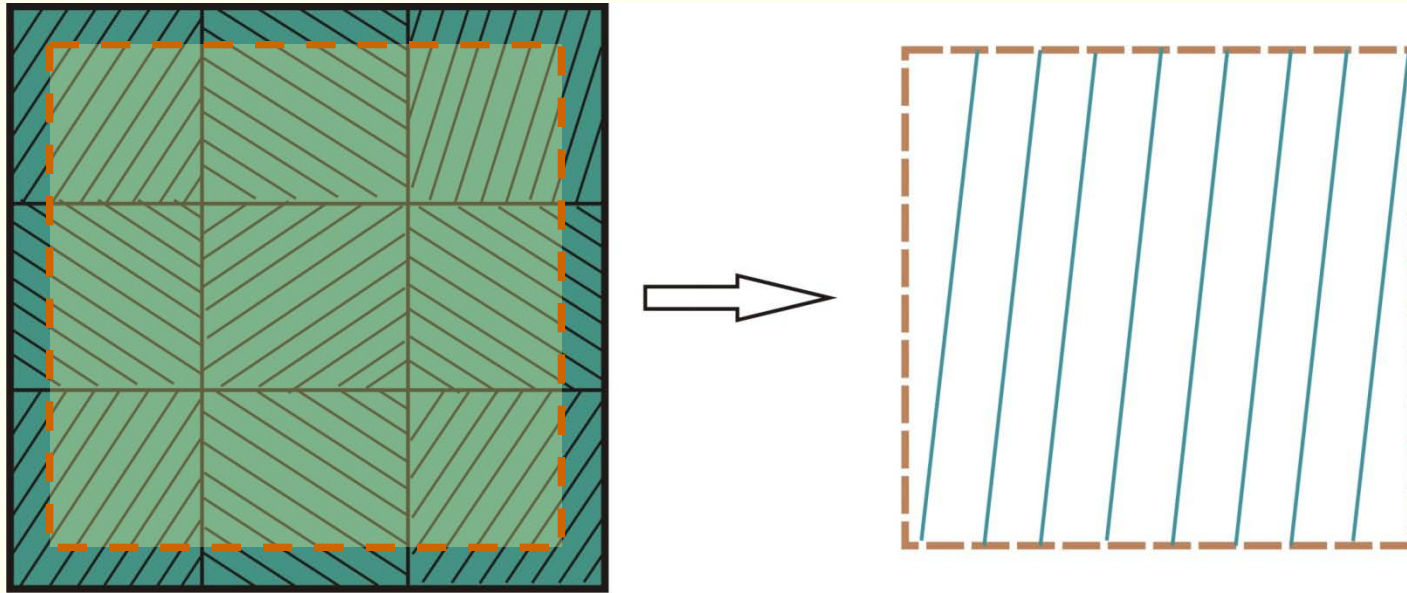

# step 4

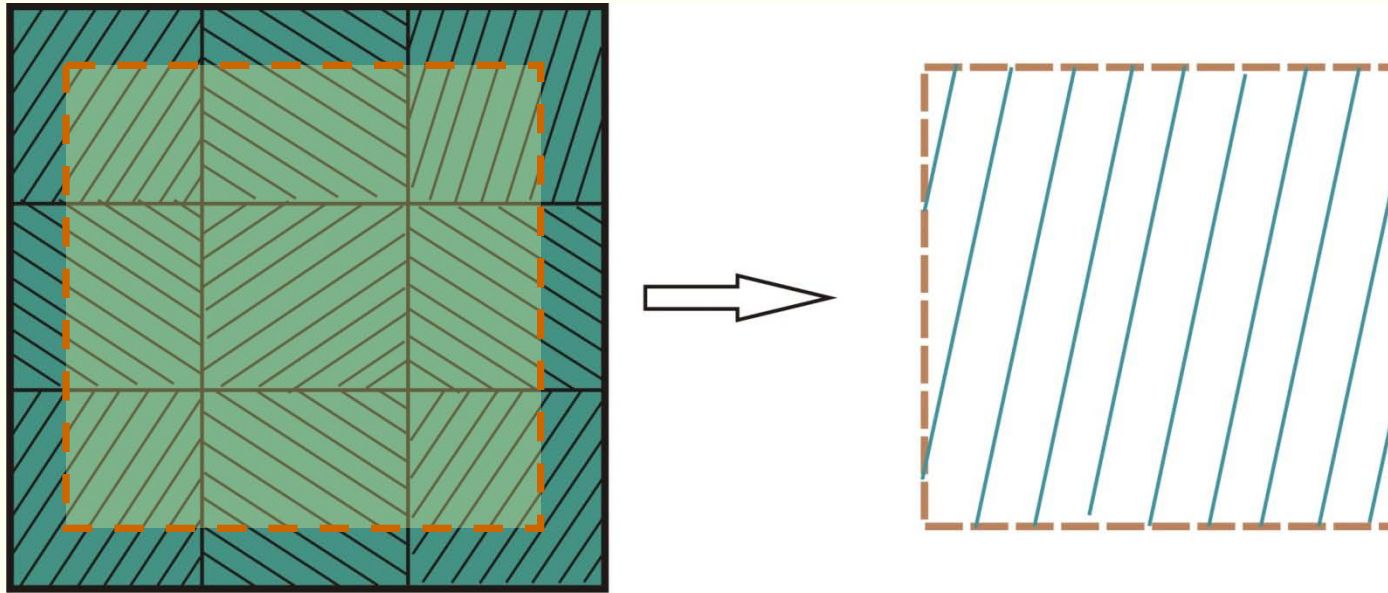

# step 5

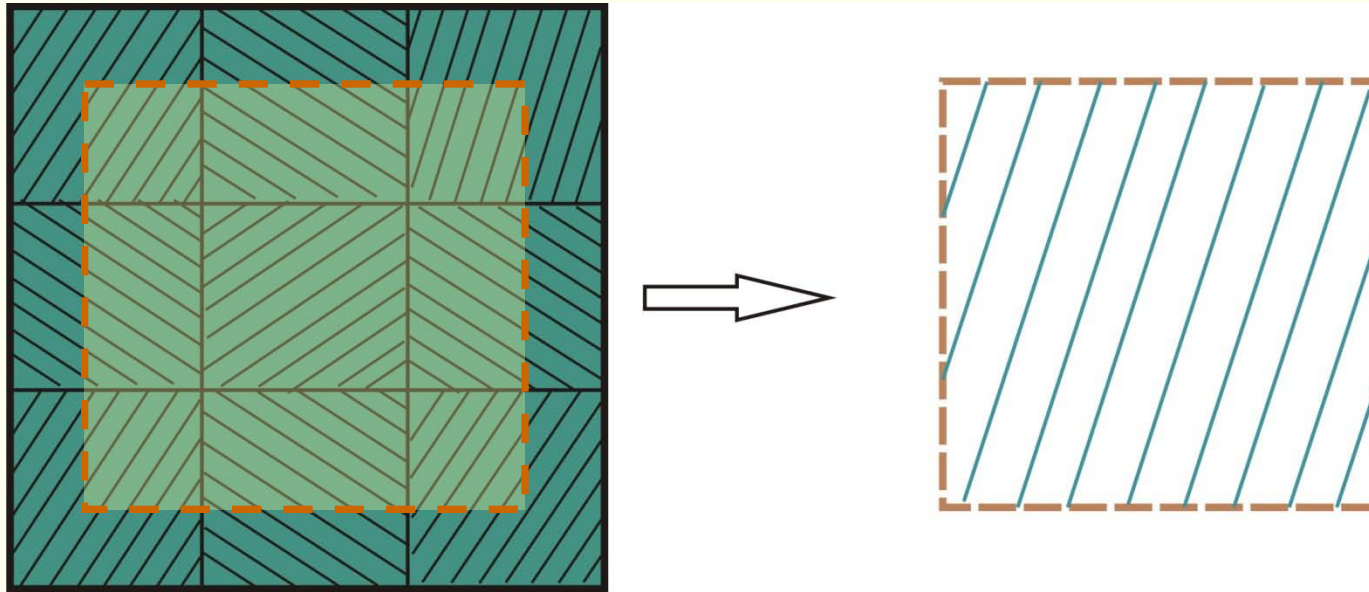

# step 6

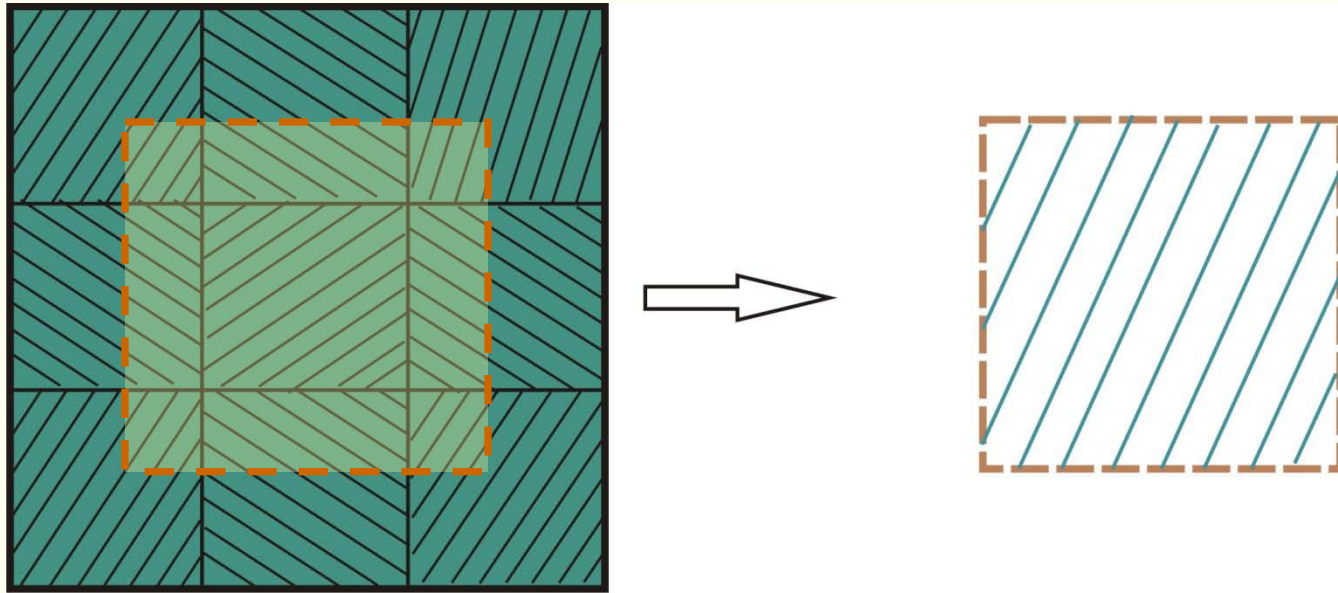

# step 7

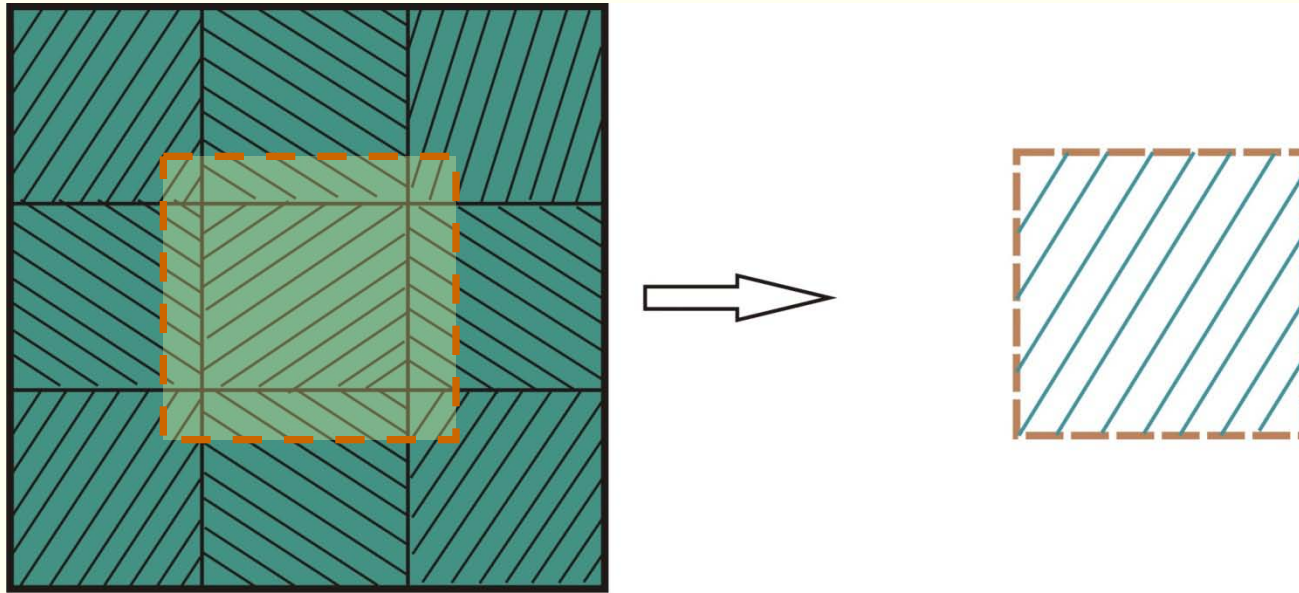

# step 8

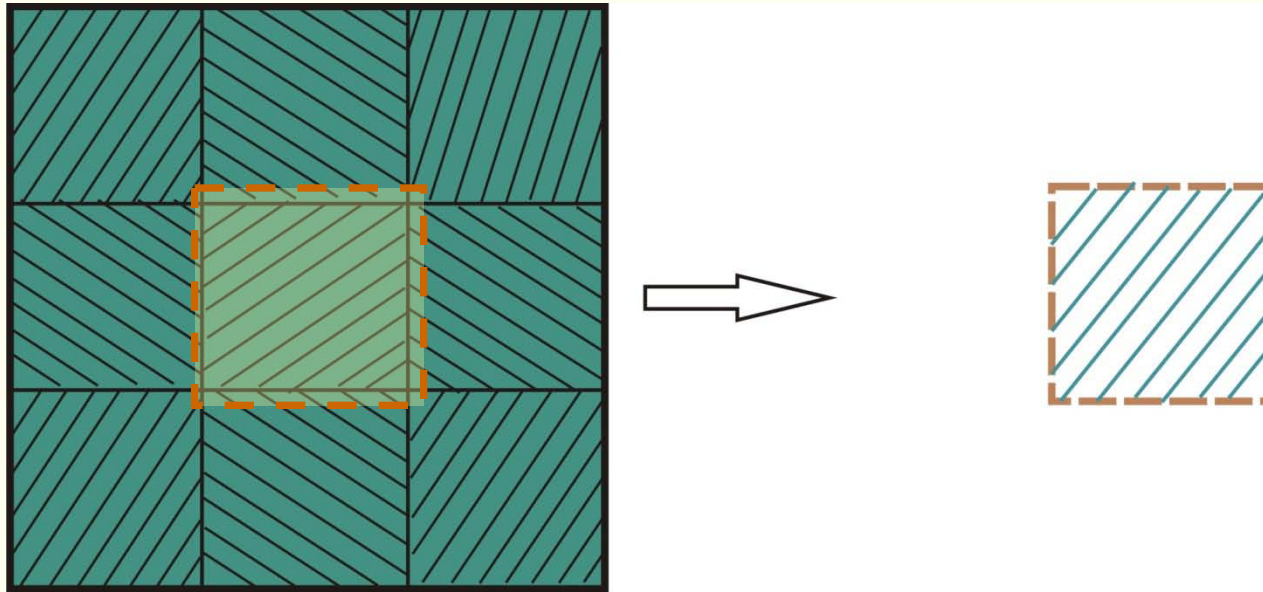

# step 9 (minimal size – single grain)

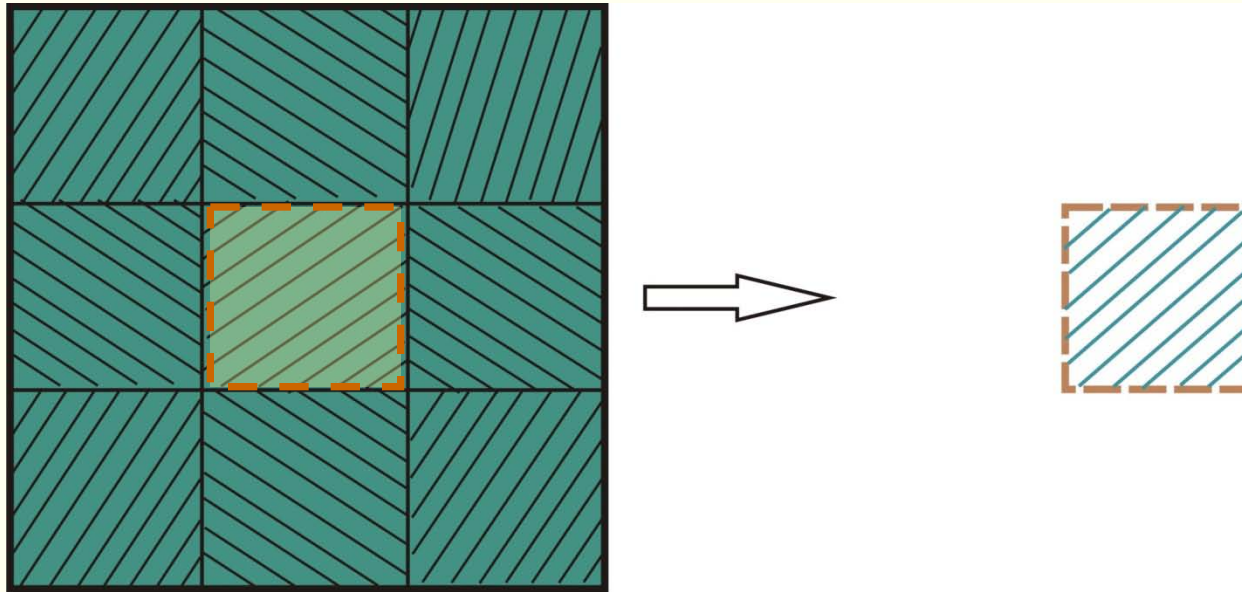

# Symmetry of bone (Cowin, Rietbergen, Telega,...)

